

Smart IoT Box

IP66
Firm Structure
Modular Installation



Designed for the Outdoor Environment



Rainproof



Heat Dissipation



Lightning Protection



Dustproof



Firm Structure



Modular Installation



Anti-corrosion



Products	WI-IOTBOX01	WI-IOTBOX02
Dimensions		
Overall Size (W*H*D)	300*400*200mm	400*600*250mm
Inner Size(W*H*D)	250*350*190mm	350*560*240mm
Weight(kg)	10	15.8
Standard Parameter		
Thickness	1.2mm	
Material	SUS/Stainless Steel	
Color	Light Grey + Grey	
Model	WI-IOTBOX01 WI-IOTBOX02	
Protect Level	IP66, IK10	
Door	1	
Electrical Install	WI-IOTBOX02 Plate*3	
Surface Treatment	Electrostatic Spraying	
Installation	Junction, Distribution, Electrical, Battery, Control, Monitoring etc. Outdoor waterproof Enclosure Box	

All-weather Outdoor Electrical Equipment Protection Box



Flexible and Easy Installation Method Design

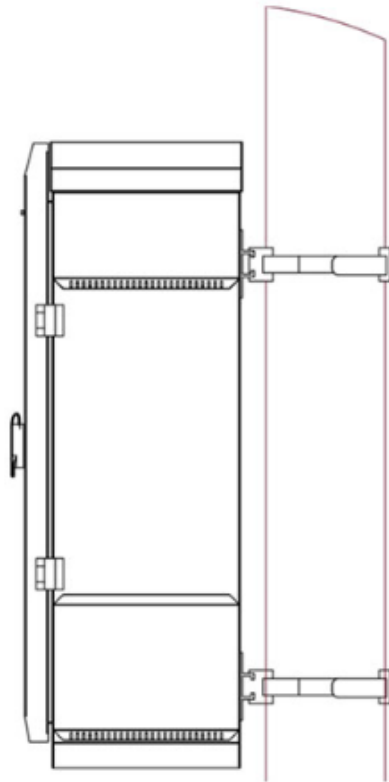

Pole-mounted

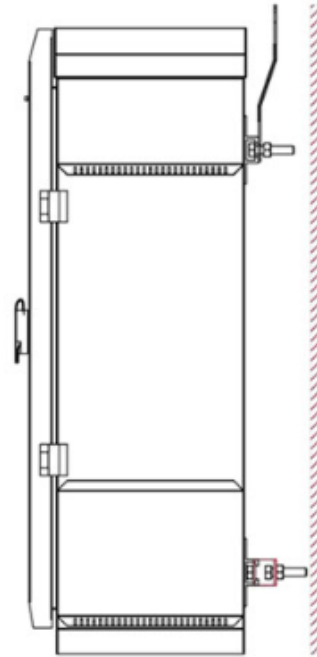

Wall-mounted

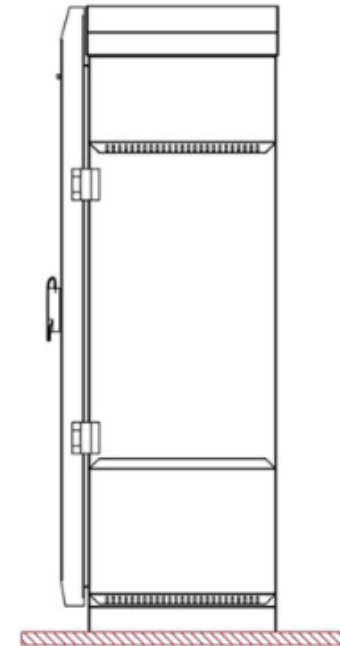

Floor-type

Application of WI-IOTBOX01

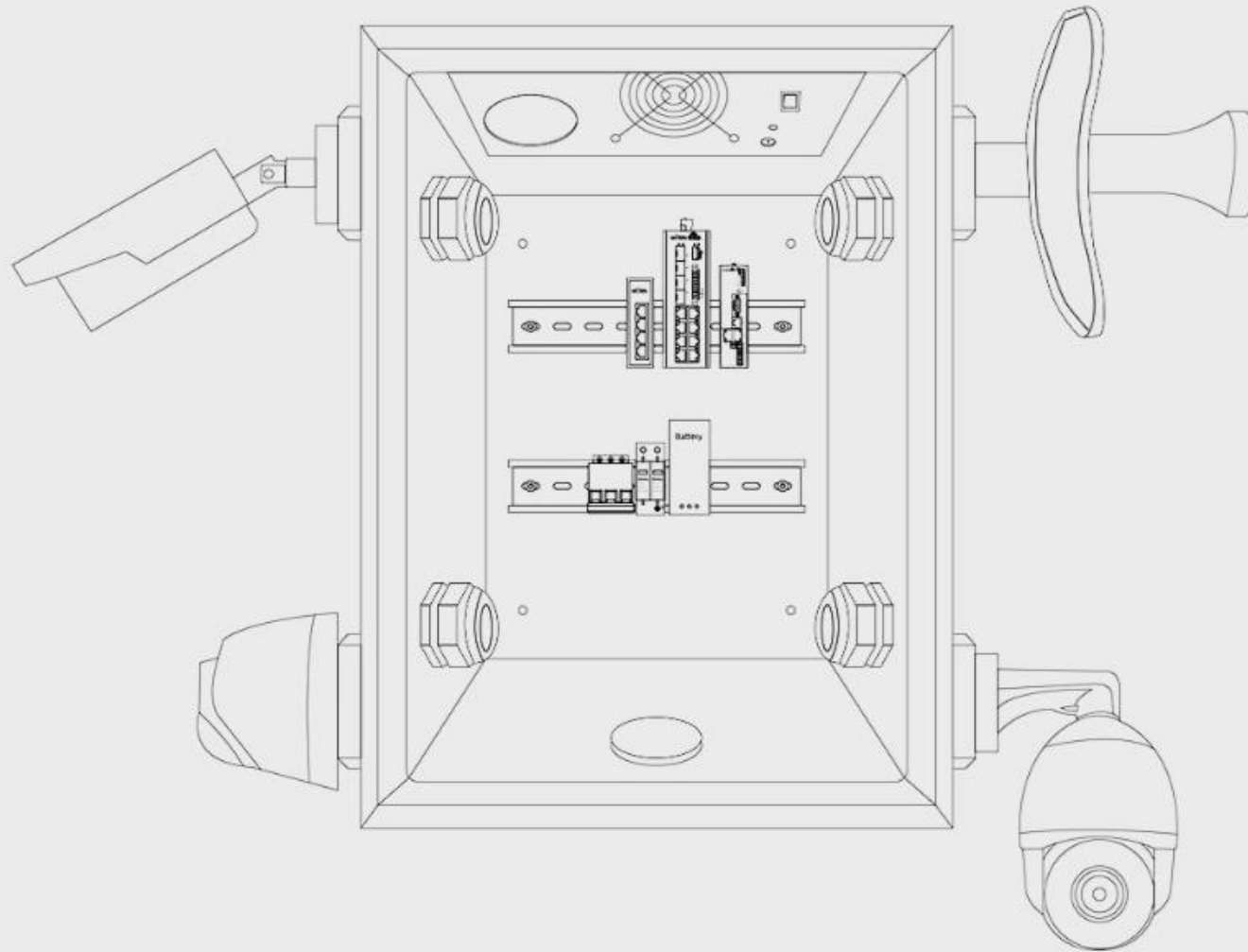

Application of WI-IOTBOX02

